

PICCADILLY LINE

FINSBURY PARK TO HAMMERSMITH circa MAY 1931

These diagrams show the signalling arrangements on the original section of the Piccadilly Line between Finsbury Park and Hammersmith as it was in mid May 1931. By this stage some track and signalling alterations have already been carried out in connection with the forthcoming Piccadilly Line extensions, particularly at the western end of the line. To highlight some of these changes some sections of the line are also shown as they were in 1907.

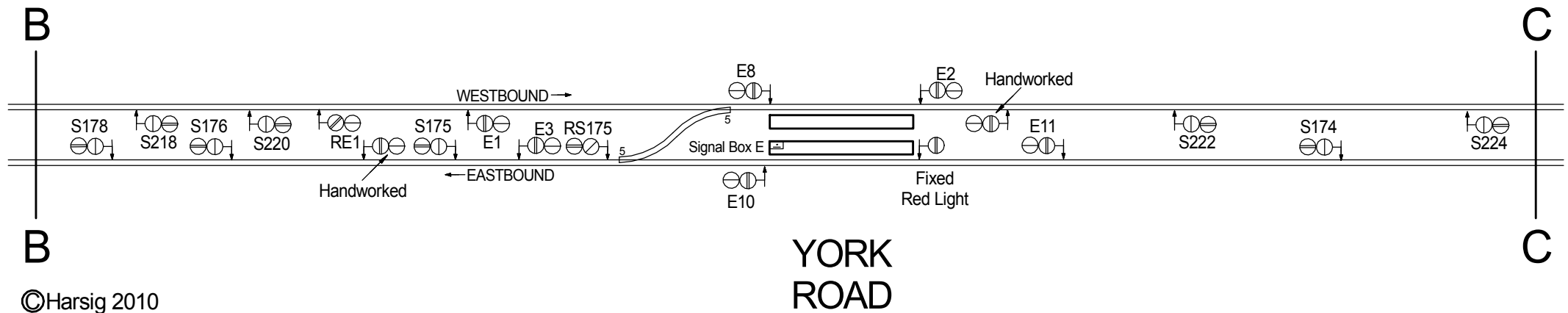

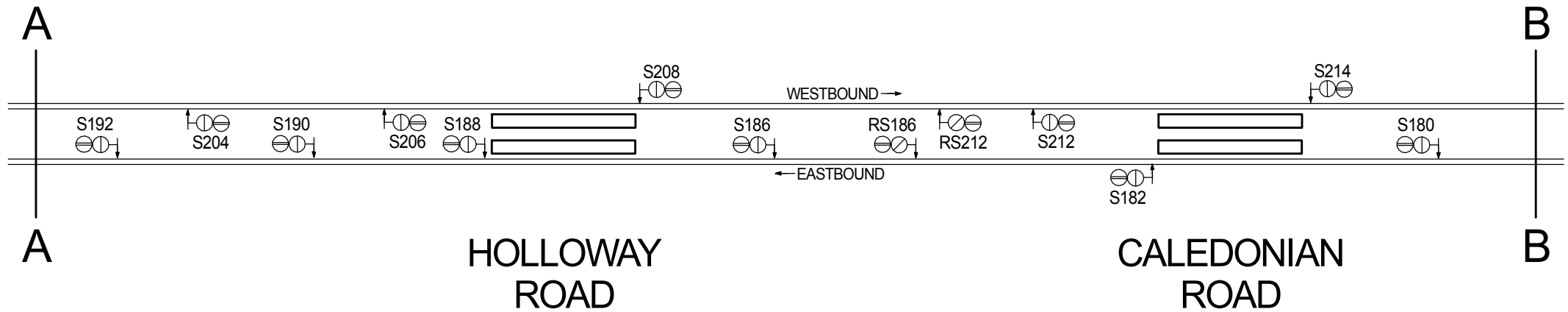
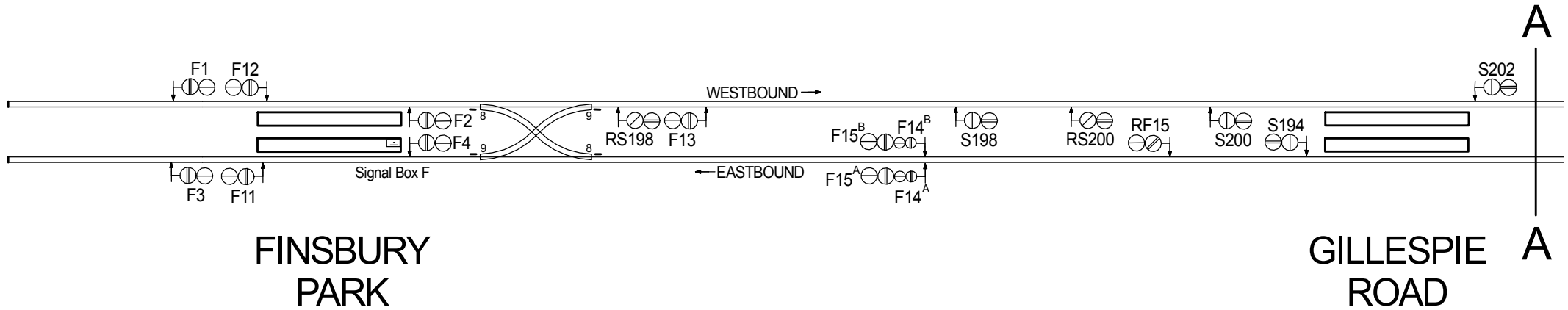
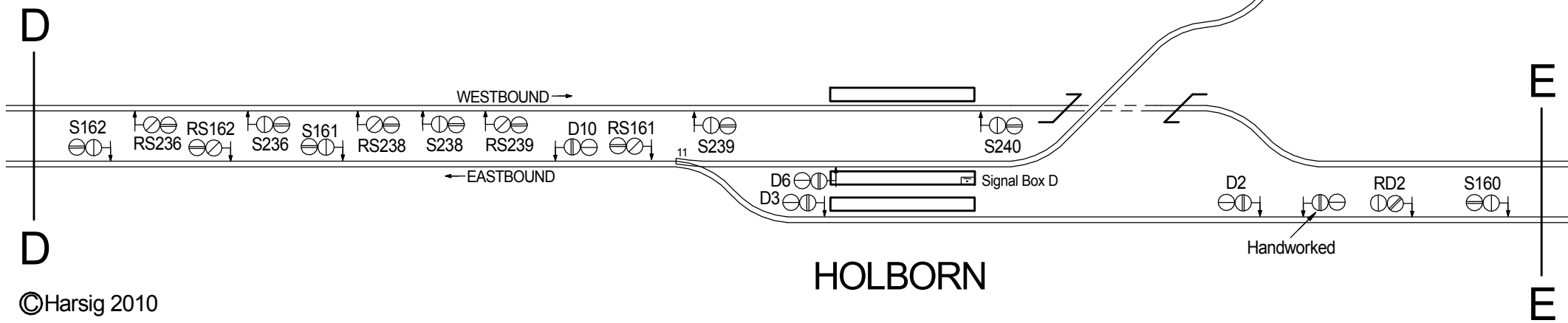
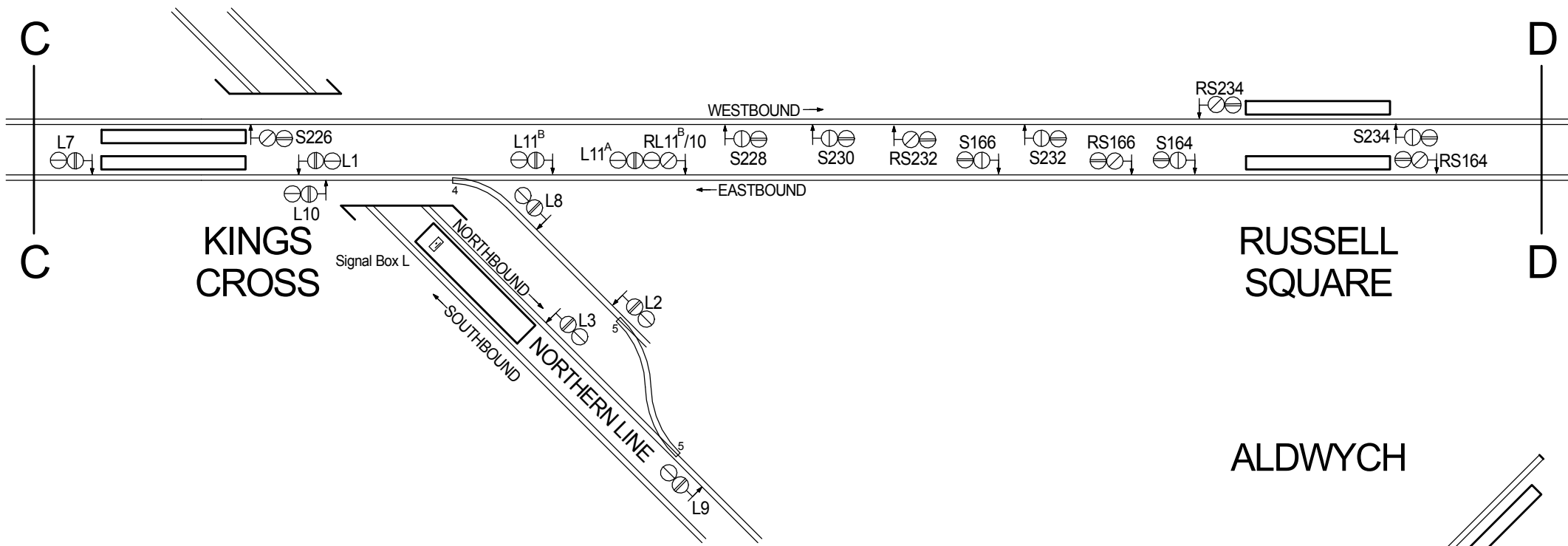

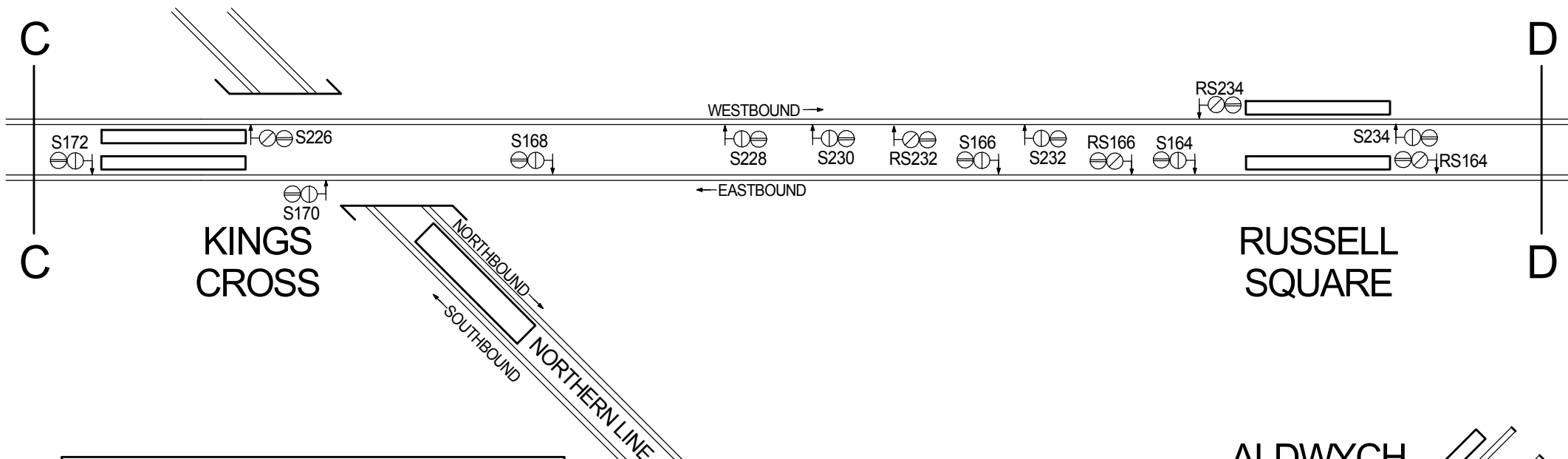

1907
 Details of Automatic Signalling
 may not be correct

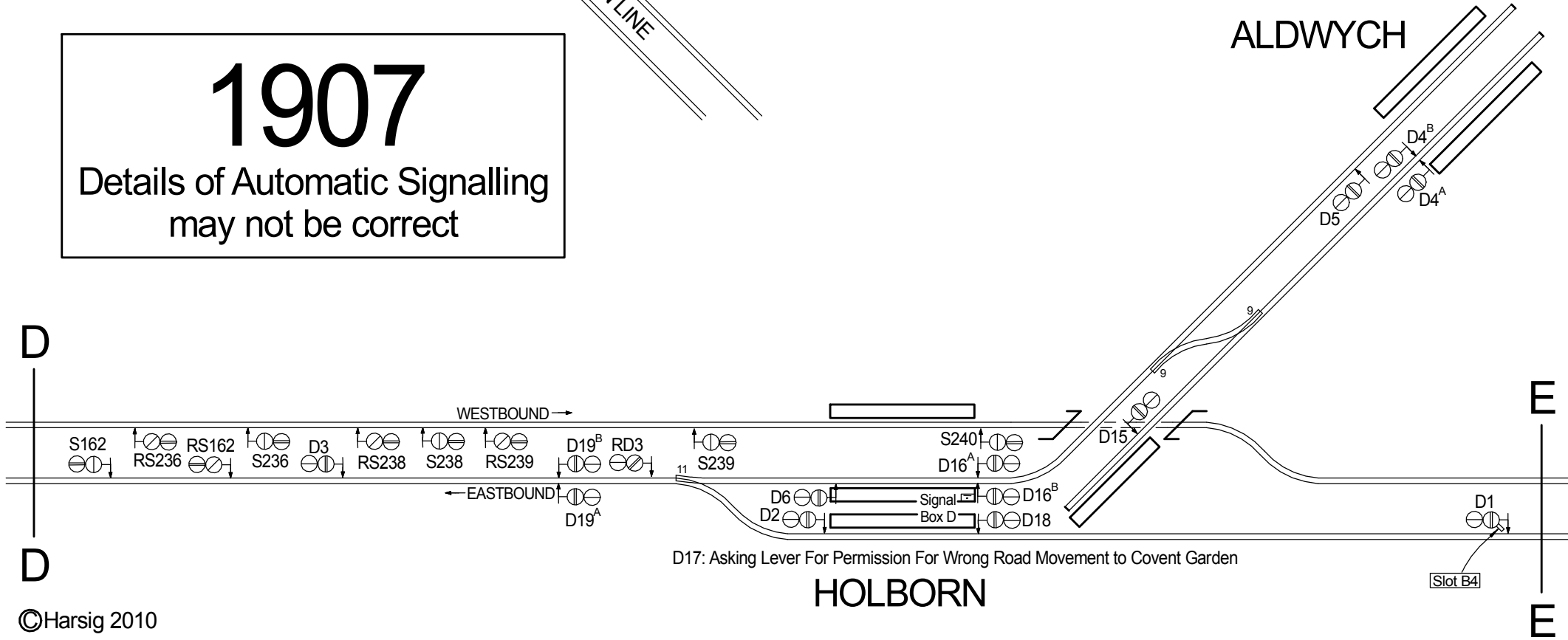

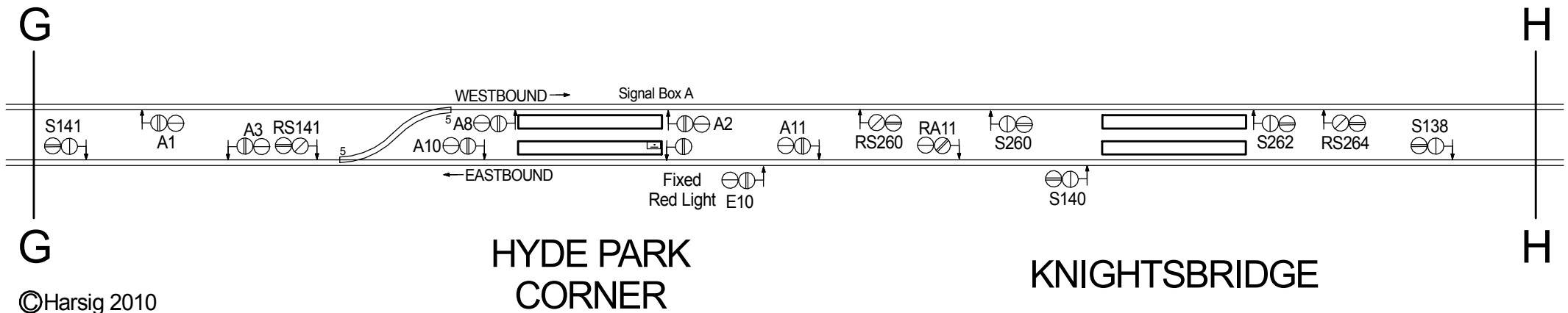
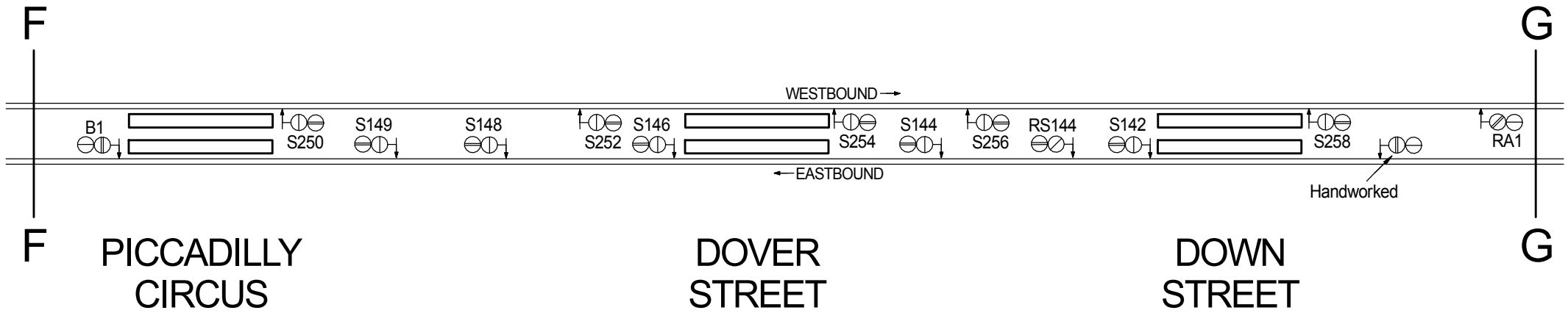
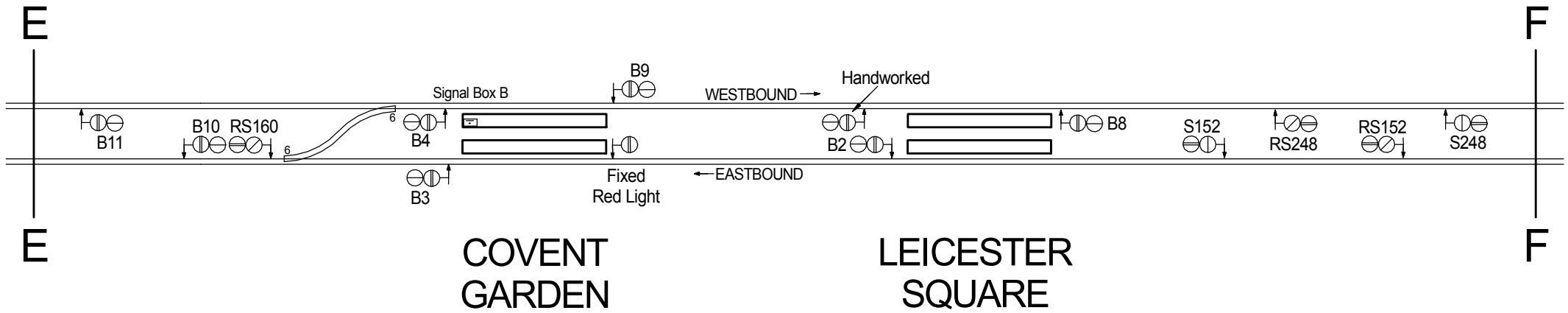

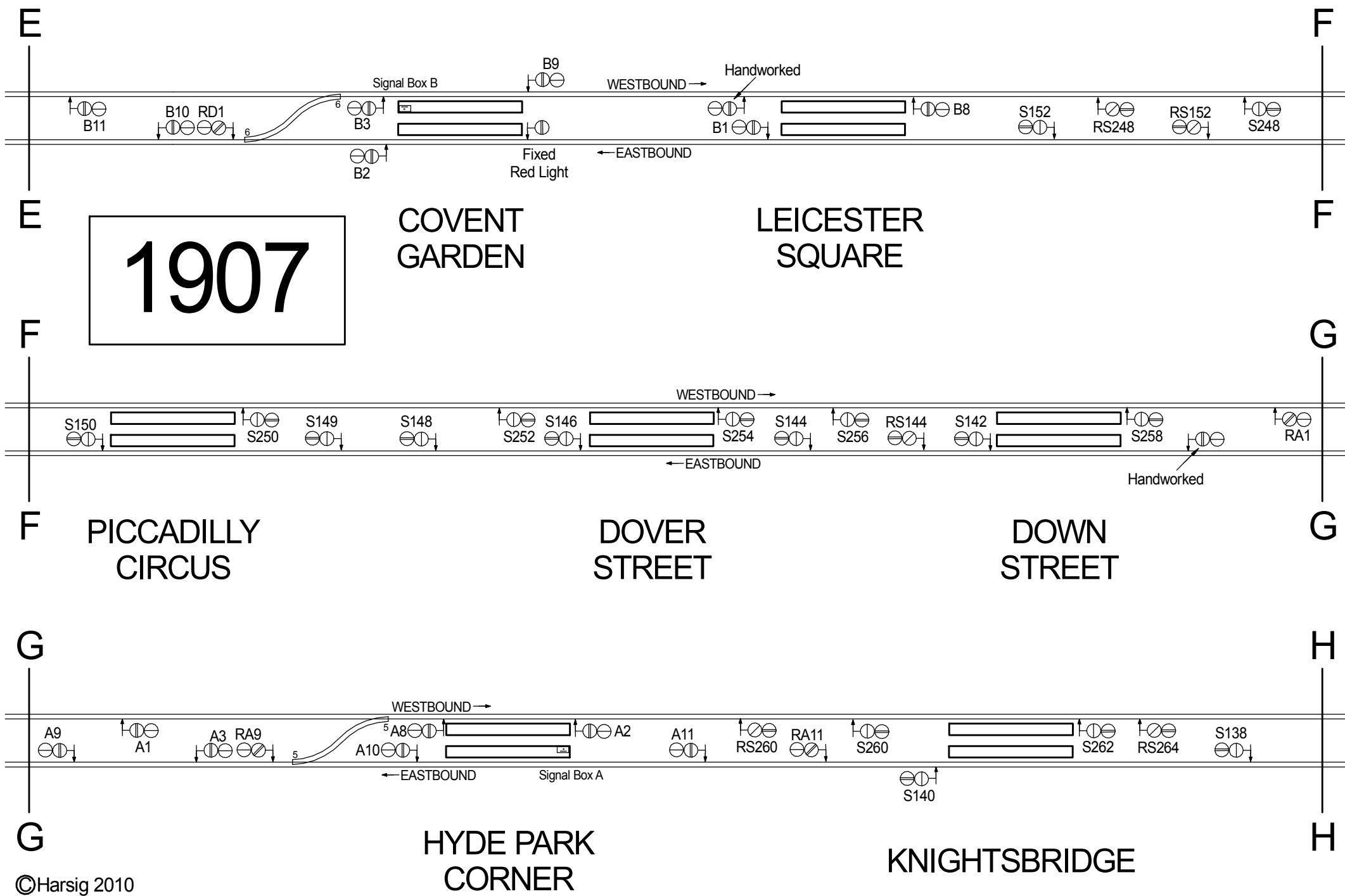

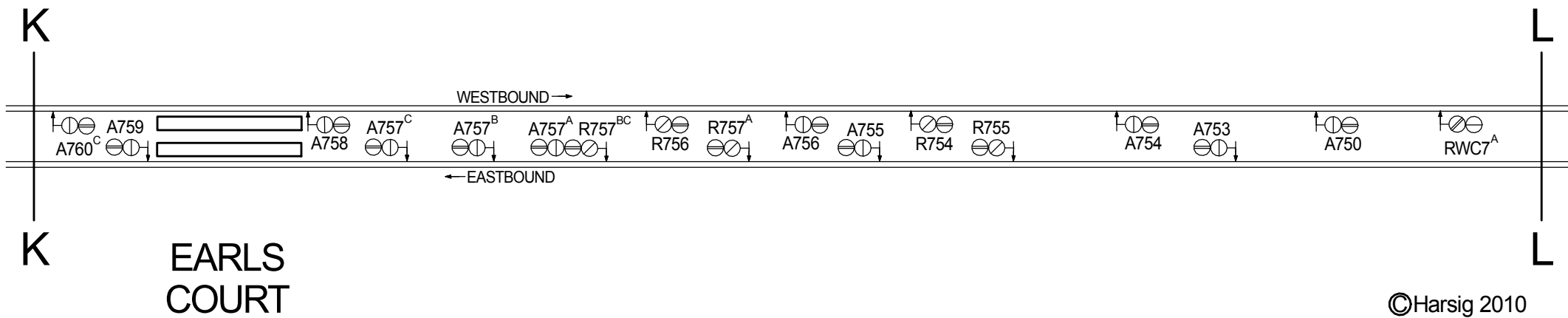
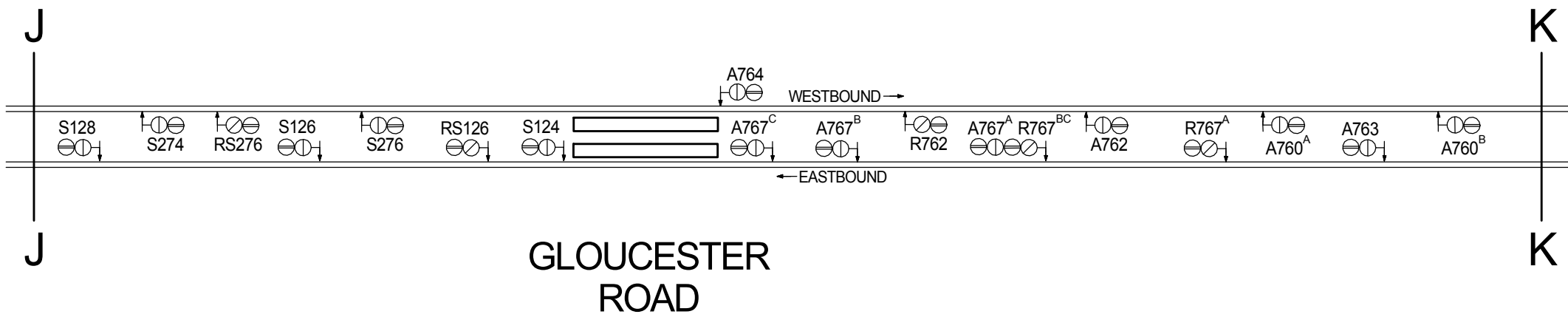
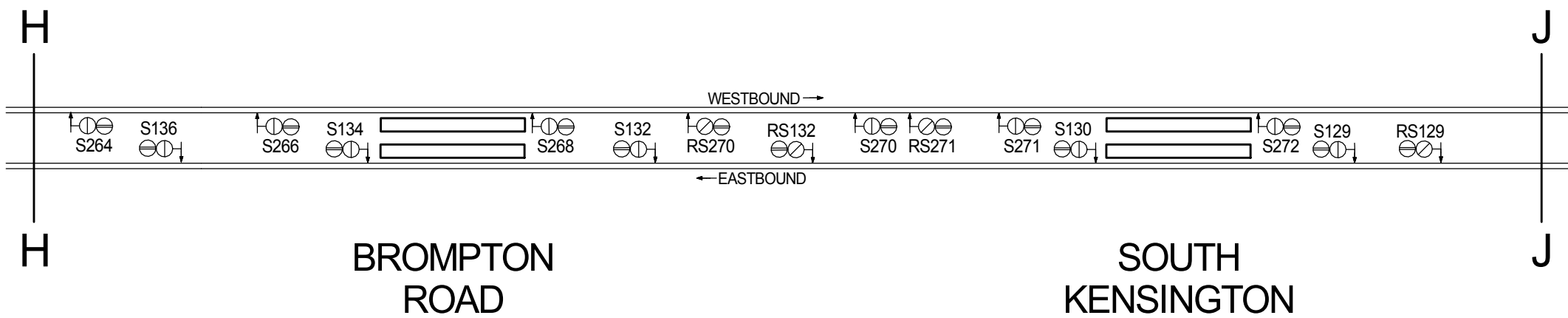

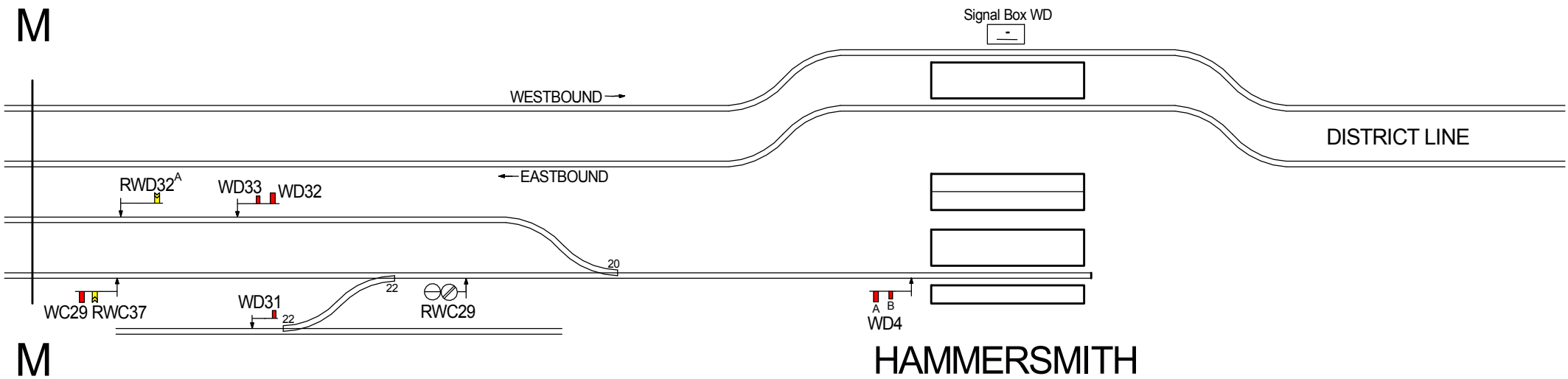
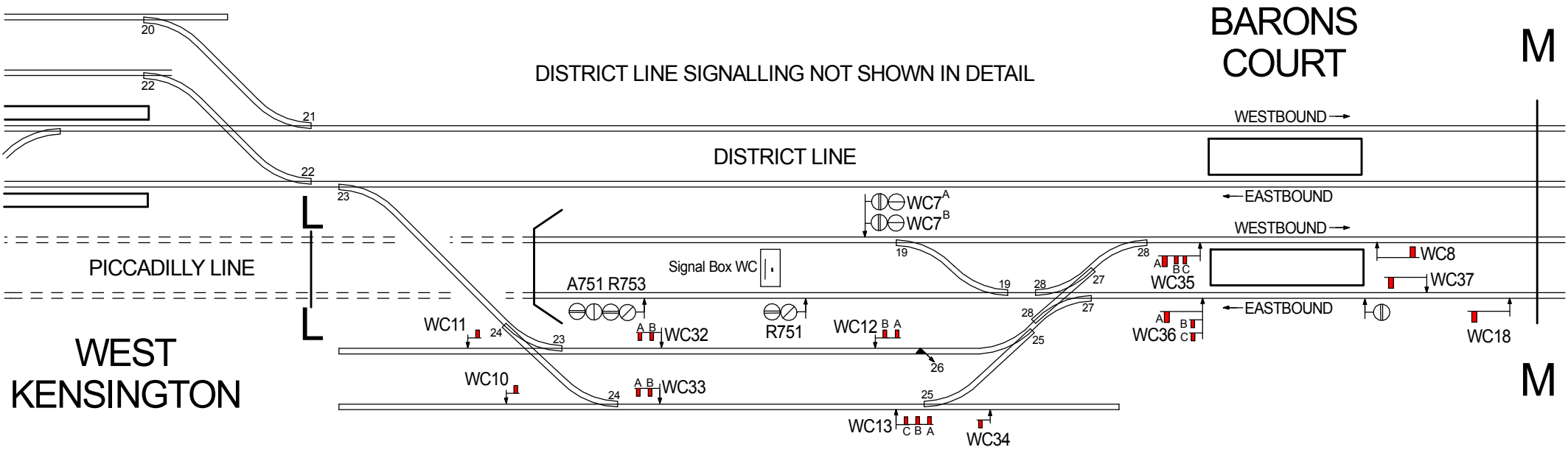

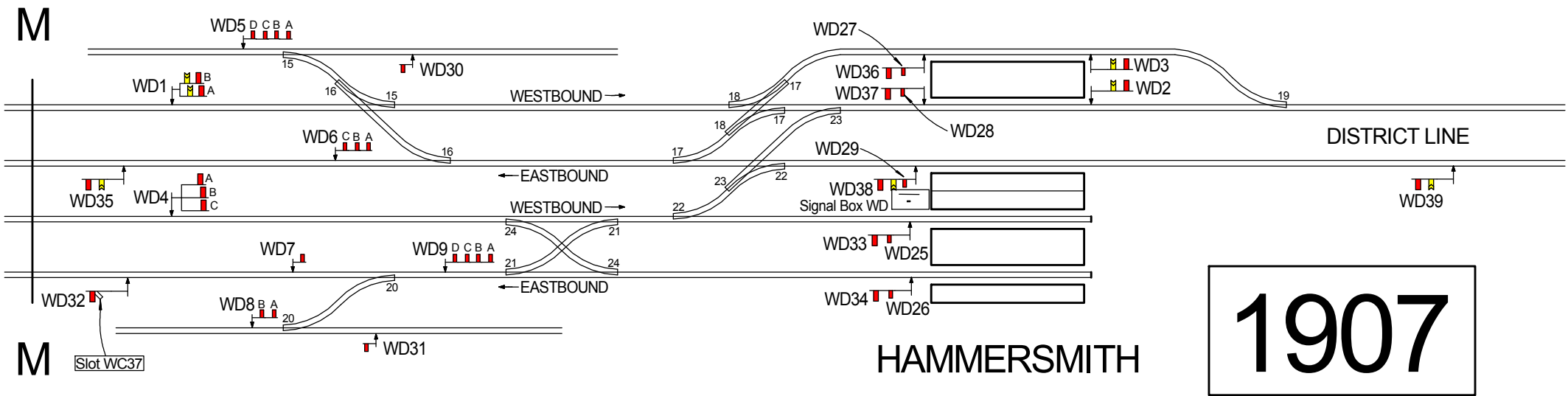
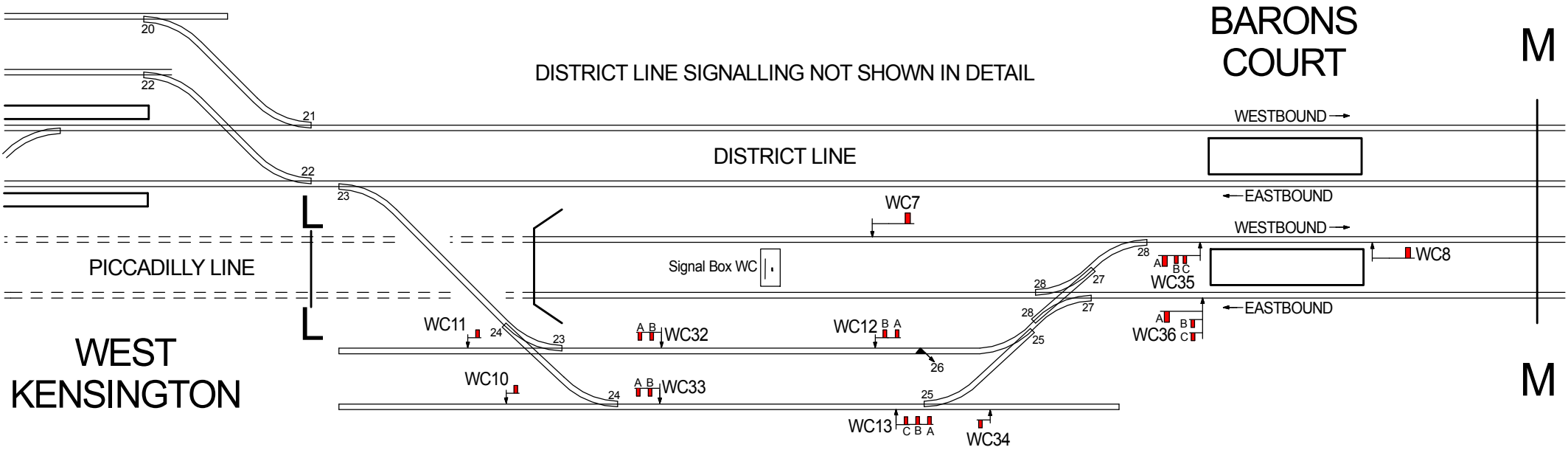

1907